

Adjustments

⚠ Warning!

Before riding, always make sure that the basic settings made by Öhlins are according to recommended Set-up Data. Read about adjustments and setting up in the Öhlins Owner's Manual before you make any adjustments. Contact an Öhlins dealer if you have any questions about setting up the shock absorber.

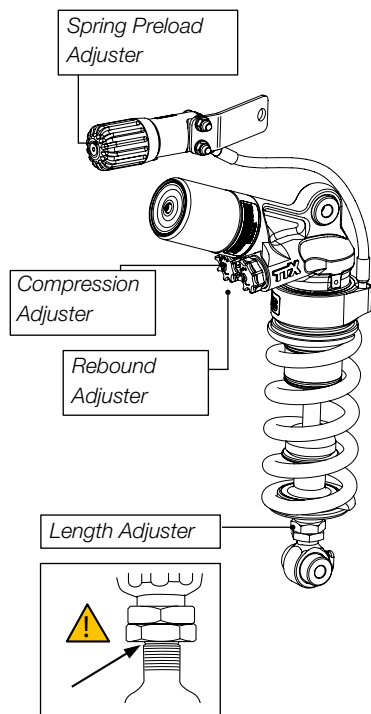

Set-up Data

Recommended set-up

Spring Preload 14 mm
Rebound 13 clicks
Compression 10 clicks

Total length 302 ⁺⁴/₋₂ mm
Stroke 60 mm
Spring 21040-36
Spring; Free length 160 ⁰/₋₃ mm
Spring rate 105 N/mm

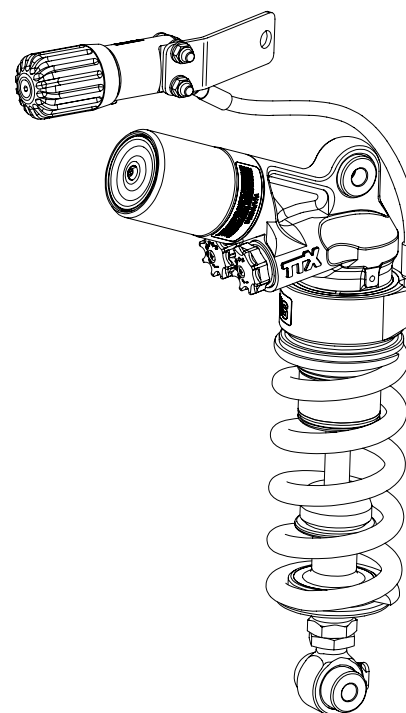

Before installing this product, check the contents of the kit. If anything is missing, please contact your nearest Öhlins dealer.

Kit Contents

	Part No.	Pcs.
Shock absorber	HO888	1
Screw M10x35	01239-05	1
Öhlins Sticker	00192-01	2
Memo Notes Sticker	01180-01	1
Owner's Manual	07242-01	1

Please note that during storage and transportation, especially at high ambient temperature, some of the oil and grease used for assembling may leak and stain the packaging. This is in no way detrimental to the product, wipe off the excessive oil/grease with a cloth.

⚠ Warning!

Before installing this product, read the Öhlins Owner's Manual. The shock absorber is an important part of your vehicle and will affect the stability.

Öhlins products are subject to continuous improvement and development, therefore, although these instructions include the most up-to-date information available at the time of printing, minor updates may occur.

To find the latest information contact your Öhlins distributor. Please consult your Öhlins dealer if you have any questions regarding the contents in this document.

Part no. HO888_1
Issued 2009-10-29



Shock Absorber for Honda CBR 1000 RR HO 888

Mounting Instructions

© Öhlins Racing AB. All rights reserved. Any reprinting or unauthorized use without the written permission of Öhlins Racing AB is prohibited.

Öhlins Racing AB
Box 722
S-194 27 Upplands Väsby, Sweden
Phone +46 8 590 025 00
fax +46 8 590 025 80



www.ohlins.com



⚠ Warning!

It is advisable to have an Öhlins dealer install the shock absorber.

When installing, consult your Vehicle Service Manual.

1
Put the motorcycle on a workstand so that the rear wheel barely touches the ground.

⚠ Warning!

Make sure the vehicle is securely supported so that it will not tip.

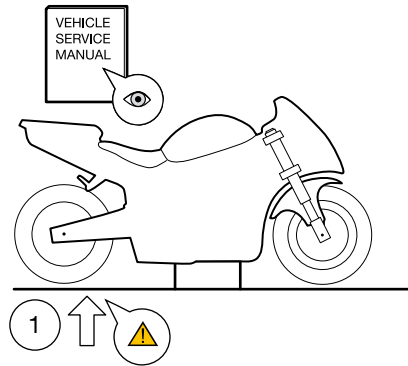

2
Remove the fairing screw at bottom rear on the left hand side.

3
Dismantle the lambda cable clip from the frame.

4
Undo the expup cable from it's guidance behind the rear brake fluid reservoir.

5
Loosen and move the silencer to the right as much as possible. Be careful with the lambda and expup cable.

6
Remove the shock screws and link screw from the swing arm.

7
Remove the shock absorber downwards.

👁 Note!

Before installing the Öhlins shock absorber:

- clean the vehicle thoroughly
- adjust the length of the shock absorber (check the headlight angle after adjusting the length!)

8
Install the Öhlins shock absorber in reverse order.

9
Remove the lower left rear subframe screw. Use the screw provided in this kit and install the hydraulic preload adjuster on the inside. Rotate it upwards as much as possible before tightening the nut.

👁 Note!

Lower the motorcycle so that the shock absorber is slightly compressed, before tightening the screws.

👁 Note!

Make sure that all removed parts are installed in the same way as they were before the installation.

👋 Caution!

Make sure that all screws are tightened to the correct torque and that nothing fouls or restricts movement of the shock absorber when the suspension is fully compressed or extended.

